



1,5" Ceramic Dome Tweeter

Program Power	300 W
Rated impedance	8 Ohm
Nominal diameter	1,5" - 38 mm
Sensitivity (2,83V/1m)	94 dB
Voice coil diameter	1,5 in - 38 mm
Frequency Range	1500-20000 Hz

SPECIFICATIONS

Nominal Diameter	1,5" - 38 mm
Rated Impedance	8 Ohm
Nominal Power Handling ¹	120 W
Program Power ²	300 W
Sensitivity ³	94 dB
Frequency Range ⁴	1500-20000 Hz
Minimum Impedance	-
Flange material	-
Magnet Material	Ferrite
Diaphragm Material	-
Diaphragm Shape	-
Surround	-
Voice Coil Diameter	1,5 in - 38 mm
Voice Coil Winding Material	-
Voice Coil Former Material	Kapton
Flux Density	-
Ferrofluid	No
Connection type	-
Recommended Crossover Frequency	-

FREQUENCY RESPONSE AND IMPEDANCE CURVE ^{6 7}

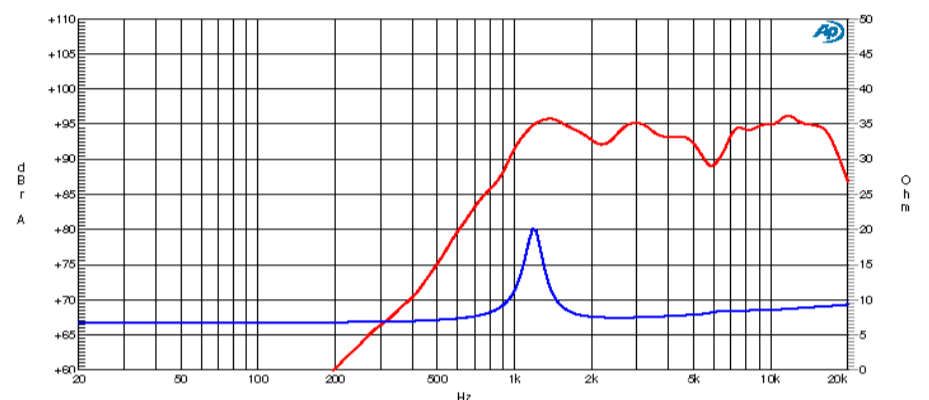

T/S PARAMETERS

8 Ohm

Resonance frequency	Fs	1000 Hz
DC Resistance	Re	5,5 Ohm
Mechanical Q Factor	Qms	5,53
Electrical Q Factor	Qes	1,92
Total Q Factor	Qts	1,42
BI Factor	Bl	-
Effective Moving Mass	Mms	-
Suspension Compliance	Cms	-
Effective Piston Diameter	D	41 mm - 1,61 in
Effective piston area	Sd	13 cm ² - 2,02 sq in
Voice Coil Inductance @ 1kHz	Le	0,09 mH

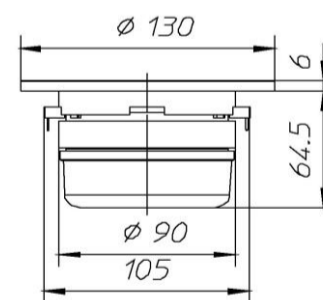

MOUNTING AND SHIPPING INFORMATION

Overall Diameter	130 mm - 5,12 in
Baffle Cutout Diameter	94 mm - 3,7 in
Flange Thickness	6 mm - 0,24 in
Total Depth	70,5 mm - 2,78 in
Bolt Circle Diameter	103 mm - 4,06 in
Bolt Holes Quantity and Diameter	4 / 5 mm - 0,2 in
Net Weight	1,1 Kg - 2,42 lb
Shipping Units	6 Pcs

NOTES

- ¹ Nominal power is determined according to AES2-1984 (r2003) standard.
- ² Program Power is defined as 3 dB greater than the Nominal rating.
- ³ Sensitivity represents the averaged value of acoustic output as measured on the forward central axis of cone, at distance 1m, when connected to 2,83V sine wave test signal.
- ⁴ Frequency range is given as the band of frequencies delineated by the lower and upper limits where the output level drops by 10 dB below the rated sensitivity in half space environment.
- ⁵ Linear Math. Xmax is calculated as (Hvc-Hg)/2 + Hg/4 where Hvc is the coil depth and Hg is the gapdepth.
- ⁶ Frequency response curve is measured on IEC Baffle.
- ⁷ Impedance curve is measured in free air conditions at small signals.